

Model	MX-F251			
	CFV	RFV	KKV	AFV
1 Front Casing	CFRETFE			
2 Impeller	CFRETFE			
3 Rear Casing	CFRETFE			
4 Magnet capsule	CFRETFE			
5 O-ring	FKM ¹			
6 Spindle	High Purity Alumina Ceramic	SIC	High Purity Alumina Ceramic	
7 Bearing	Carbon	PTFE	SIC	High Purity Alumina Ceramic
8 Rear thrust	CFRETFE			
9 Mouth ring	PTFE	SIC	PTFE	
10 Thrust/Liner ring	Alumina Ceramic	SIC	High Purity Alumina Ceramic	

1 EPDM and AFLAS® o-ring also available

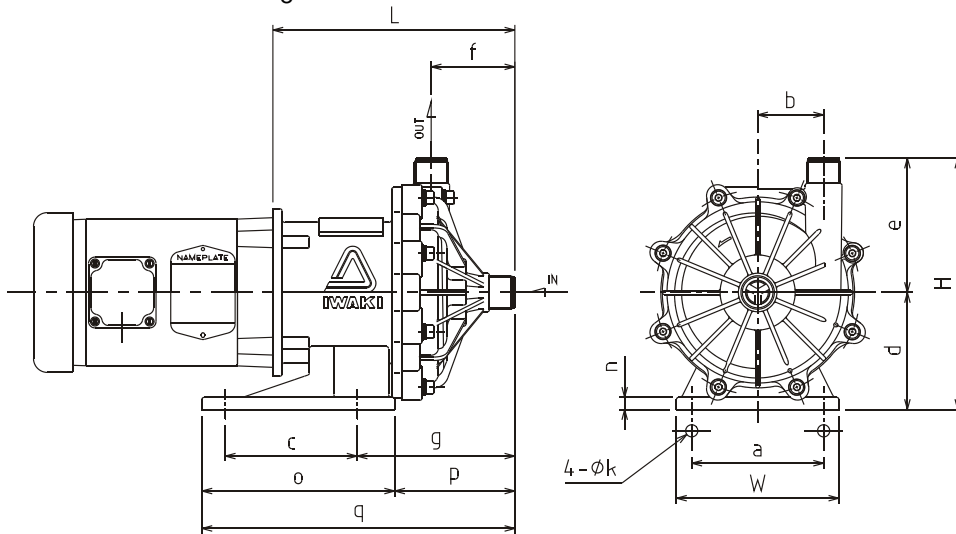

Dimensions (in inches)

a	b	c	d	e	f	g	k	n	o	p	q	W	H	L
5.12	2.56	53.12	4.53	5.22	3.25	6.12	0.47	0.47	7.48	4.67	12.15	6.30	9.75	9.39

Specifications

Suction x Discharge	Max Discharge pressure	Max Flow	Specific gravity	Weight (less motor)
1" x 1"	69 FT	40 GPM	1.0	22.5 lbs

MX-F251 1 HP

- Engineered to meet the most severe operating conditions.
- When fitted with a carbon bearing, the MX will allow for brief periods of dry running.
- The MX Series is the first resin magnet pump that uses a Split Volute Pump Casing that forms a vortex chamber.
- Patented Self-radiating structure – Heat dispersion holes force the liquid to circulate around the spindle and bearing.

MX-F251

