

1 2 3 4 5 6 7 8 9 10 11 12 13 14 15 16 17 18 19 20 21 22 23 24 25

PART OR DRAWING NO. IF20568 REV. A

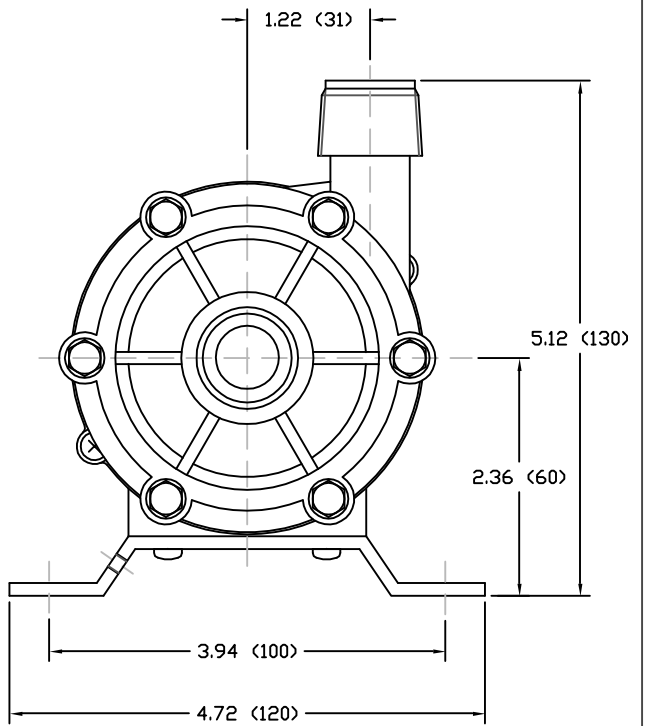
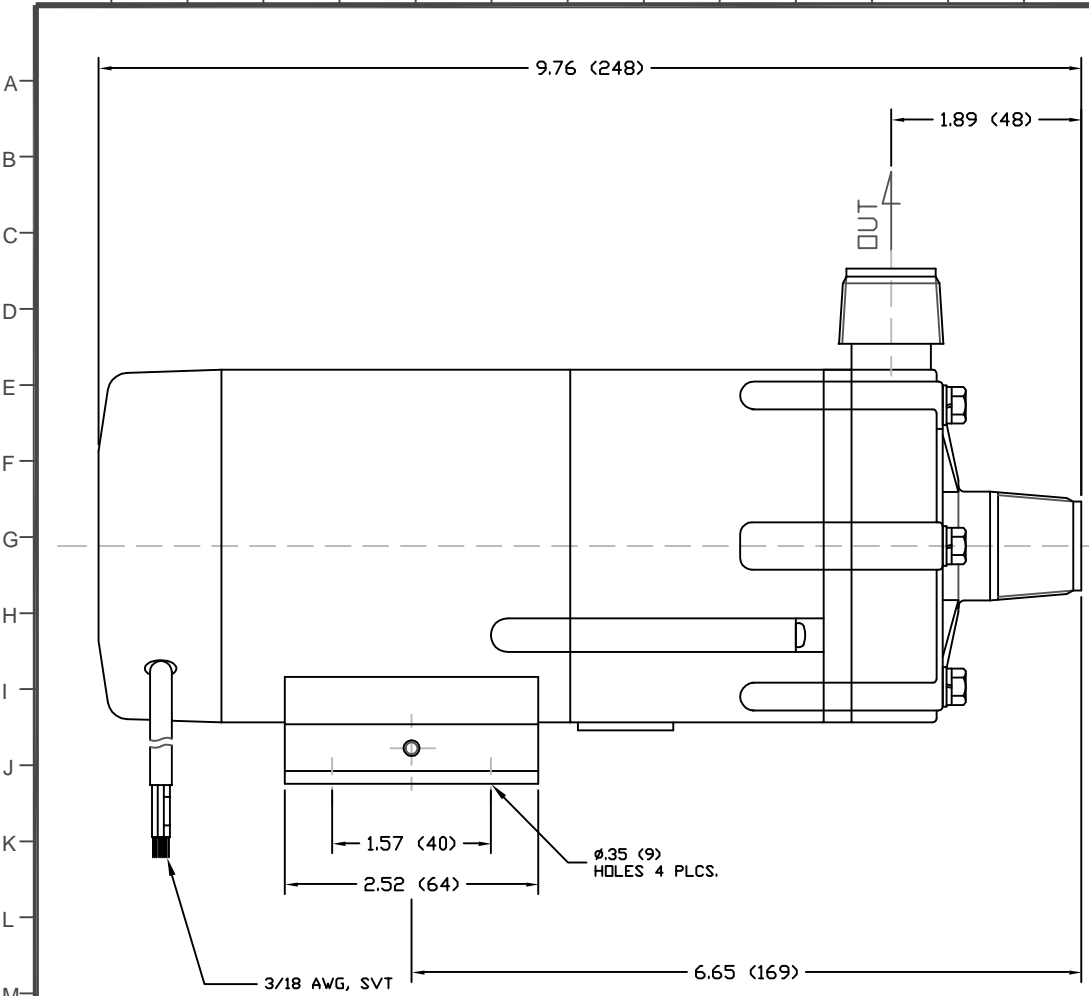

- NOTES:
 1. DRAWING MAY VARY FROM ACTUAL PRODUCT
 2. DRAWN FROM 22000409 TO SCALE.
 3. REFER TO SPECIFICATION C910710.
 4. DIMENSIONS ARE IN INCHES (MM).

SPECIFICATIONS

MAX CAPACITY	10 GPM (37.9 LPM)
MAX HEAD	17.7 FT (5.39 M)
MAWP	11.6 PSI (.08 MPA)
VOLTAGE	115 VAC
CURRENT	0.8 A
CORD LENGTH	39.4 IN (1 M)
WEIGHT	7.7 LBS (3.49 KG)
SUCTION	3/4 IN NPT - MALE
DISCHARGE	3/4 IN NPT - MALE

MATERIALS

CASING	GFRPP
IMPELLER	GFRPP
SPINDLE	ALUMINA CERAMIC
BEARING	PTFE
THRUST RING	ALUMINA CERAMIC
O-RING	FKM

ECO#	DESCRIPTION	DATE	REV. LTR.
MATERIAL SEE CHART			
GJS	04 03 05	XXX	1
DRAWN	DAY	MO.	YR.
RELEASED		SHEET NO.	
		5 Boynton Rd. Hopping Brook Park Holliston, MA 01746 (508) 429-1440 www.IwakiAmerica.com	
TITLE			
MAG DRIVE PUMP MD-30RT (115V)			

PART OR DWG. NO. IF20568 REV. A

1 2 3 4 5 6 7 8 9 10 11 12 13 14 15 16 17 18 19 20 21 22 23 24 25

PART OR DRAWING NO. IF20569 REV. A

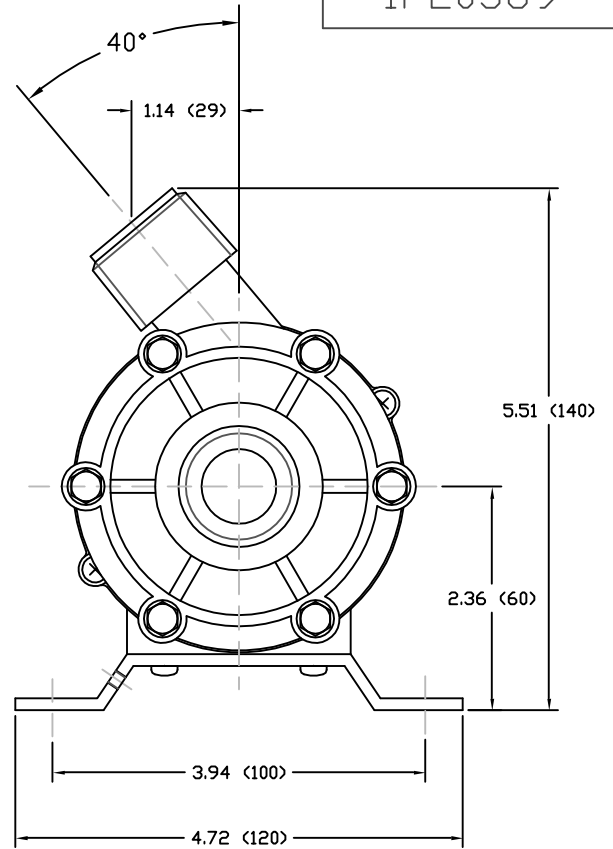
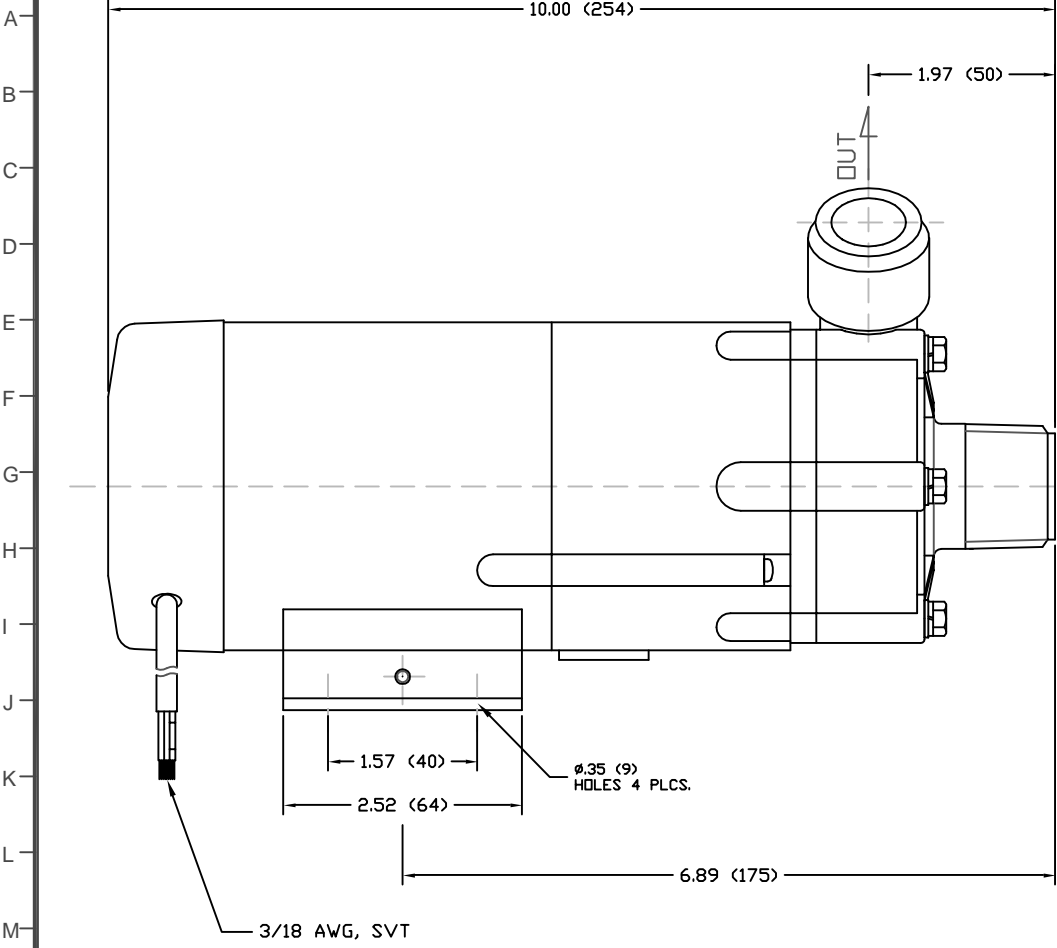

- NOTES:
 1. DRAWING MAY VARY FROM ACTUAL PRODUCT
 2. DRAWN FROM 22000410 TO SCALE.
 3. REFER TO SPECIFICATION C910705.
 4. DIMENSIONS ARE IN INCHES (MM).

SPECIFICATIONS	
MAX CAPACITY	19 GPM (72 LPM)
MAX HEAD	13.5 FT (4.11 M)
MAWP	8.54 PSI (.06 MPA)
VOLTAGE	115 VAC
CURRENT	1.1 A
CORD LENGTH	39.4 IN (1 M)
WEIGHT	7.7 LBS (3.5 KG)
SUCTION	1 IN NPT - MALE
DISCHARGE	1 IN NPT - MALE

MATERIALS

CASING	GFRPP
IMPELLER	GFRPP
SPINDLE	ALUMINA CERAMIC
BEARING	PTFE
THRUST RING	ALUMINA CERAMIC
O-RING	FKM

ECO#	DESCRIPTION	DATE	REV. LTR.
MATERIAL SEE CHART			
GJS	04 03 05	XXX	1
DRAWN	DAY	MO.	YR.
RELEASED		SHEET NO.	
		5 Boynton Rd. Hopping Brook Park Holliston, MA 01746 (508) 429-1440 www.lwakiAmerica.com	
TITLE			
MAG DRIVE PUMP			
MD-30RXT (115V)			

PART OR DWG. NO. IF20569

REV. A

1 2 3 4 5 6 7 8 9 10 11 12 13 14 15 16 17 18 19 20 21 22 23 24 25

PART OR DRAWING NO. IF20570 REV. A

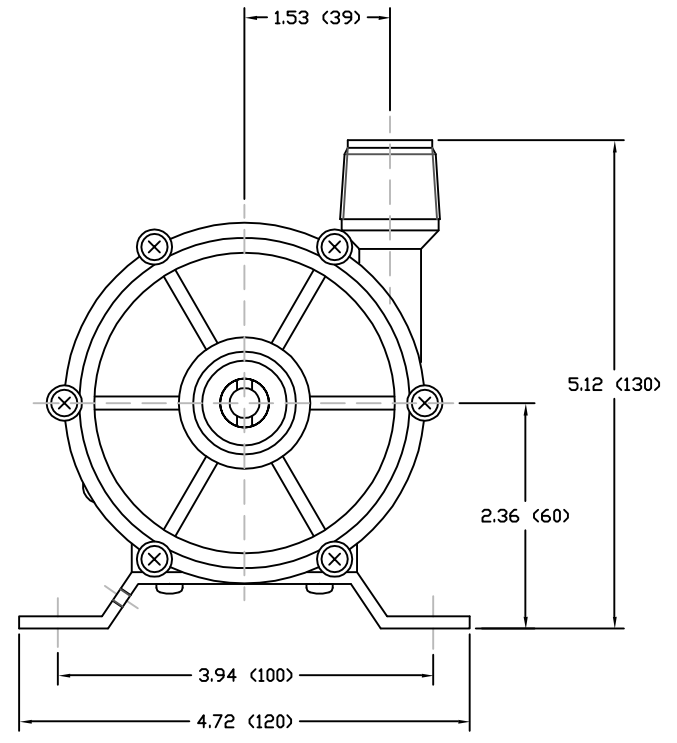
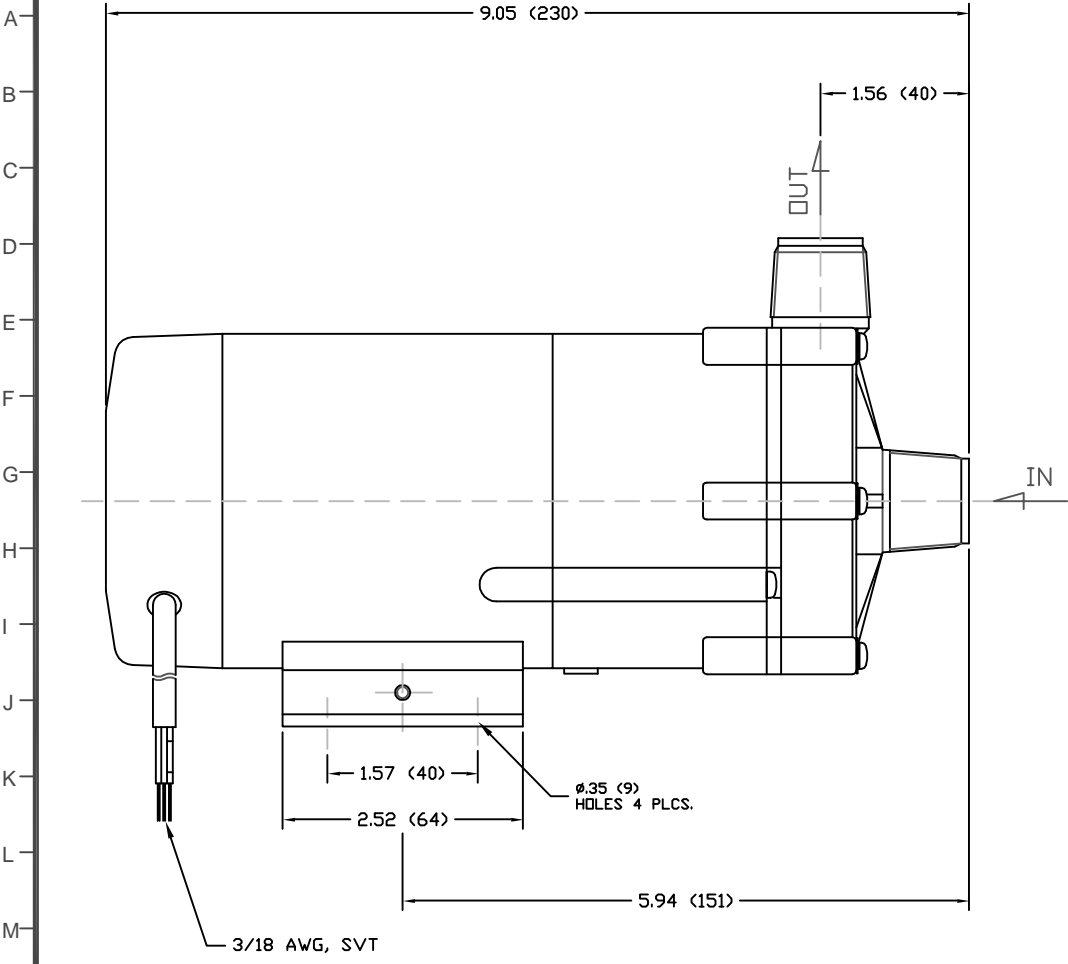

- NOTES:
 1. DRAWING MAY VARY FROM ACTUAL PRODUCT
 2. DRAWN FROM 2Z000411 TO SCALE.
 3. REFER TO SPECIFICATION C910697/
 4. DIMENSIONS ARE IN INCHES (MM).

SPECIFICATIONS	
MAX CAPACITY	4.5 GPM (17 LPM)
MAX HEAD	36.1 FT (11 M)
MAWP	24.18 PSI (.17 MPA)
VOLTAGE	115/220 VAC
CURRENT	1.1/0.4 A
CORD LENGTH	39.4 IN (1 M)
WEIGHT	7.7 LBS (3.49 KG)
SUCTION	3/4 IN NPT - MALE
DISCHARGE	3/4 IN NPT - MALE

MATERIALS	
CASING	GFRPP
IMPELLER	GFRPP
SPINDLE	ALUMINA CERAMIC
BEARING	PTFE
THRUST RING	ALUMINA CERAMIC
O-RING	FKM

ECO#	DESCRIPTION	DATE	REV. LTR.
MATERIAL SEE CHART			
GJS	04 03 05	XXX	1
DRAWN	DAY	MO.	YR.
		RELEASED	SHEET NO.
 www.IwakiAmerica.com		5 Boynton Rd. Hopping Brook Park Holliston, MA 01746 (508) 429-1440	
		TITLE MAG DRIVE PUMP MD-30RZT (115/220V)	

PART OR DWG. NO. IF20570 REV. A