

1 2 3 4 5 6 7 8 9 10 11 12 13 14 15 16 17 18 19 20 21 22 23 24 25

PART OR DRAWING NO. IF20605 REV. A

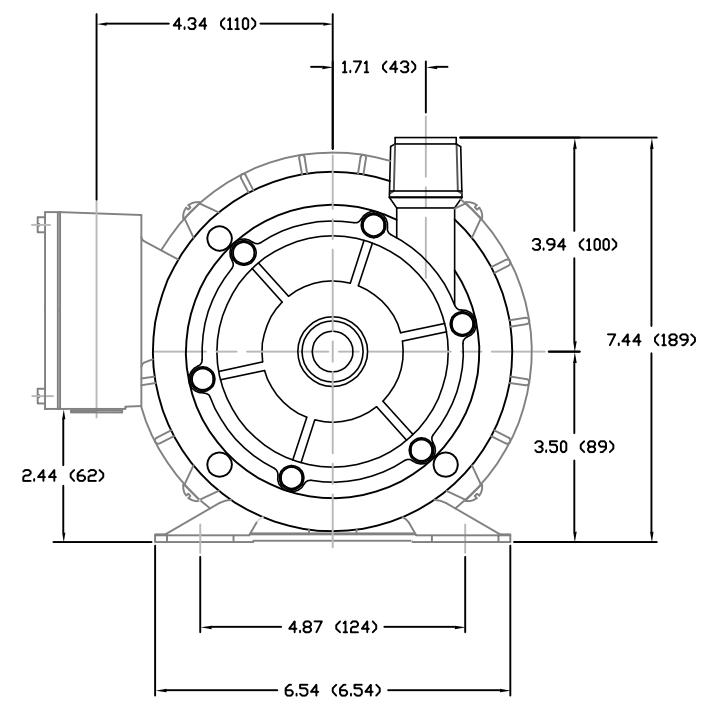
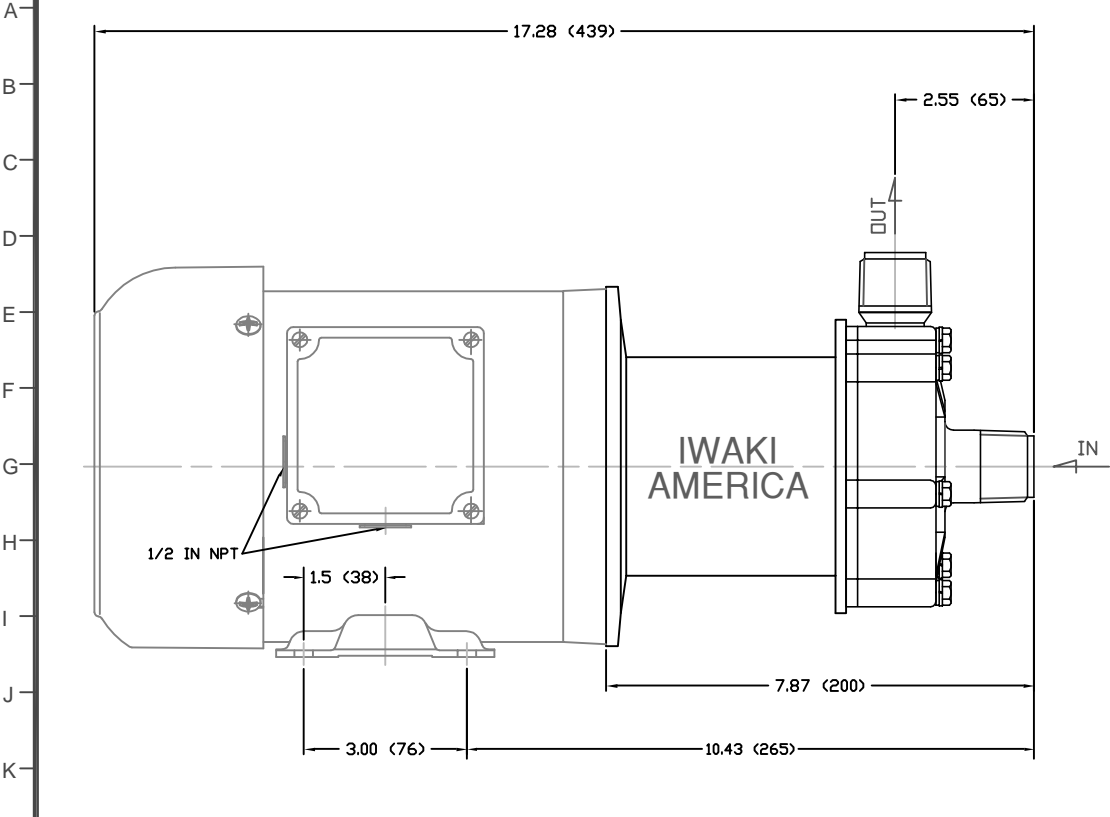

- NOTES:
 1. DRAWING MAY VARY FROM ACTUAL PRODUCT.
 2. DRAWN TO SCALE PER 2Z000375.
 3. REFER TO DRAWING 54249.
 4. MTR5001 (WEG 3336ES1BB56C) STANDARD NEMA 56C FRAMED MOTOR.
 5. DIMENSIONS ARE IN INCHES (MM)

SPECIFICATIONS	
MAX CAPACITY	35.6 GPM (135 LPM)
MAX HEAD	39 FT (11.9 M)
MAWP	25.6 PSI (.18 MPA)
VOLTAGE	115/220 VAC
CURRENT	5.7/2.85 A
CORD LENGTH	N/A
WEIGHT	28 LBS (12.7 KG)
SUCTION	1 IN NPT - MALE
DISCHARGE	1 IN NPT - MALE

MATERIALS	
CASING	GFRPP
IMPELLER	GFRPP
SPINDLE	ALUMINA CERAMIC
BEARING	PTFE
THRUST RING	ALUMINA CERAMIC
O-RING	FKM

ECO#	DESCRIPTION	DATE	REV. LTR.
MATERIAL SEE CHART			
CJC	14 04 05	XXX	1
DRAWN	DAY	MO.	YR.
		RELEASED	SHEET NO.
 www.IwakiAmerica.com		5 Boynton Rd. Hopping Brook Park Holliston, MA 01746 (508) 429-1440	
		TITLE MAG DRIVE PUMP WMD-100RLT	

PART OR DWG. NO. IF20605

REV. A