

PART OR DRAWING NO. **IF20513** REV. **C**

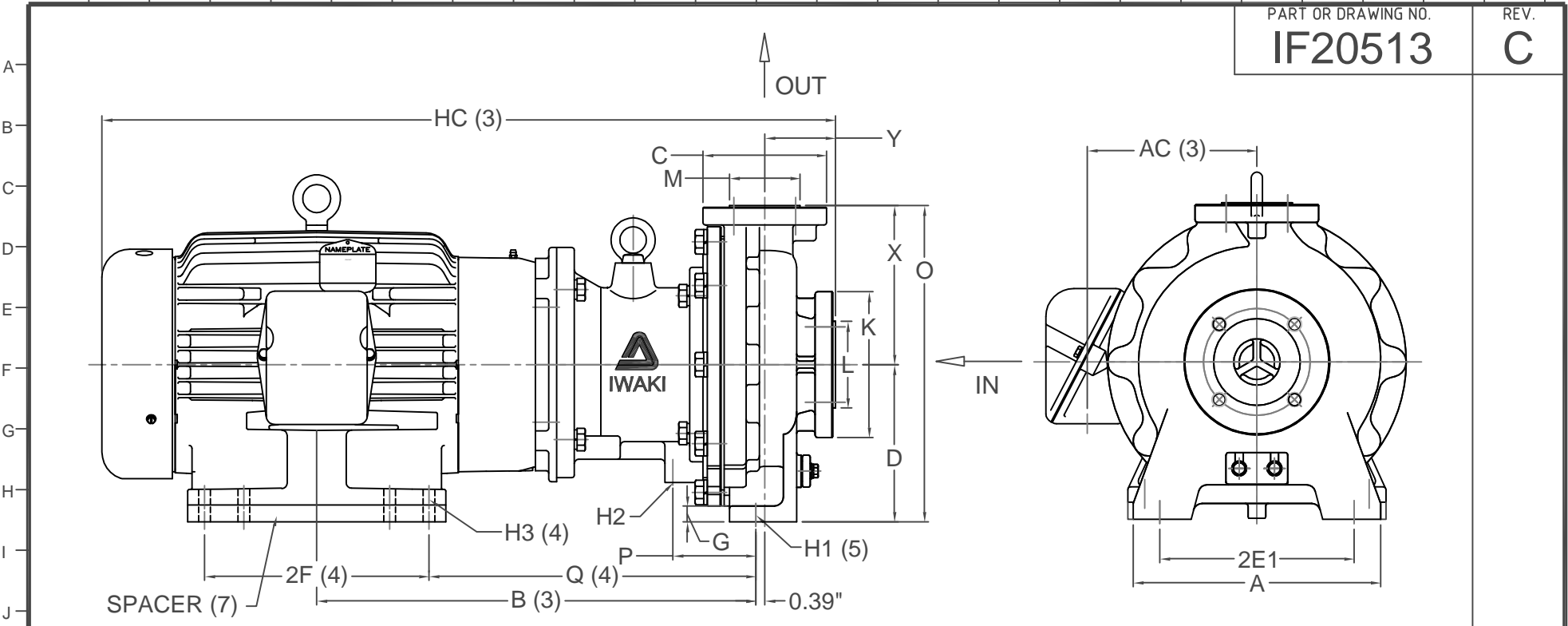

PUMP DIMENSIONS (1)															
A	AC (3)	B (3)	D	2E1	2F (4)	G	H1 (5)	H2	H3 (4)	HC (3)	O	P	Q (4)	X	Y
11.02"	7.56"	19.57"	7.00"	8.66"	8.25"/10.00"	0.70"	0.55"	3/8"-16 UNC	0.52"	32.67"	14.09"	3.70"	14.57"	7.09"	3.15"

MODEL	HP/ FRAME	PUMP FLANGES (2)		DIMENSIONS			
		SUCTION	DISCHARGE	K	L	C	M
MDM-2158	15/254TC	2"	1.5"	6.50"	3.86"	5.51"	3.15"
	20/256TC						

10630 2F DIM. CHANGED TO 10.00" 5/3/05
 10622 CENTERLINE HEIGHT CHANGED TO 7.00" 9/7/04

ECO#	DESCRIPTION	DATE	REV.	LTR.
EDT	12 07 04	CJC	1	
DRAWN	DAY MO. YR.	RELEASED	SHEET NO.	

IWAKI AMERICA
 www.IwakiAmerica.com

5 Boynton Rd.
 Hopping Brook Park
 Holliston, MA 01746
 (508) 429-1440

TITLE **MDM-2158 (15 & 20 HP)**
 Dimensional Drawing

- NOTES AND REFERENCES:**
- (1) ALL DIMENSIONS IN INCHES. ALL TOLERANCES $\pm .125"$, CONSULT IWAKI AMERICA FOR MORE DETAILS.
 - (2) BOLT HOLE LOCATIONS OF SUCTION AND DISCHARGE FLANGES CONFORM TO ANSI B16.5 150 LB STANDARD. THE 1.5" AND 2" FLANGE BOLT HOLES HAVE 1/2" -13 AND 5/8" -11 UNC THREADS RESPECTIVLY.
 - (3) DIMENSION MAY VARY BASED ON MOTOR MANUFACTURER.
 - (4) NEMA MG 1-1993, PART 4 USED FOR REFERENCE.
 - (5) SLOTS ARE OPEN ENDED TO REAR OF FRAME.
 - (6) DRAWN PER 52B402901 (MDM2158_KKF15/20A-_2)
 - (7) SPACER MDM8005, 0.75" HEIGHT WITH 1/2" THROUGH HOLES.

PART OR DWG. NO. **IF20513** REV. **C**