

MDM-326 7.5-25HP

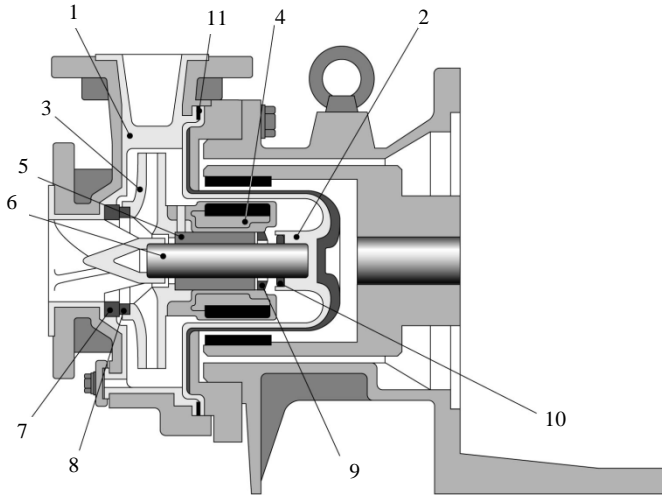

- ❑ Non-contact Bearing System allows dry run operation (CF models only)
- ❑ Simple, rugged design
- ❑ Corrosion resistant ETFE & PFA internals
- ❑ Spline/pinned impeller design (pat. pending) provides positive locking of impeller/inner magnet while still allowing for individual replacement of each part
- ❑ PFA version temperatures to 302°F

Part	Material		
	ECF	EKK	PKK
1 Front casing	CFRETFE (carbon fiber reinforced ETFE)		PFA
2 Containment shell			
3 Impeller			
4 Inner magnet assy			
5 Bearing	High density carbon	SiC	
6 Shaft	High purity alumina ceramic		
7 Front outboard thrust collar	PTFE		
8 Front inboard thrust collar			
9 Rear inboard thrust collar	High purity alumina ceramic		
10 Rear outboard thrust collar	PTFE (filler charged)	PTFE	
11 Gasket	PTFE		

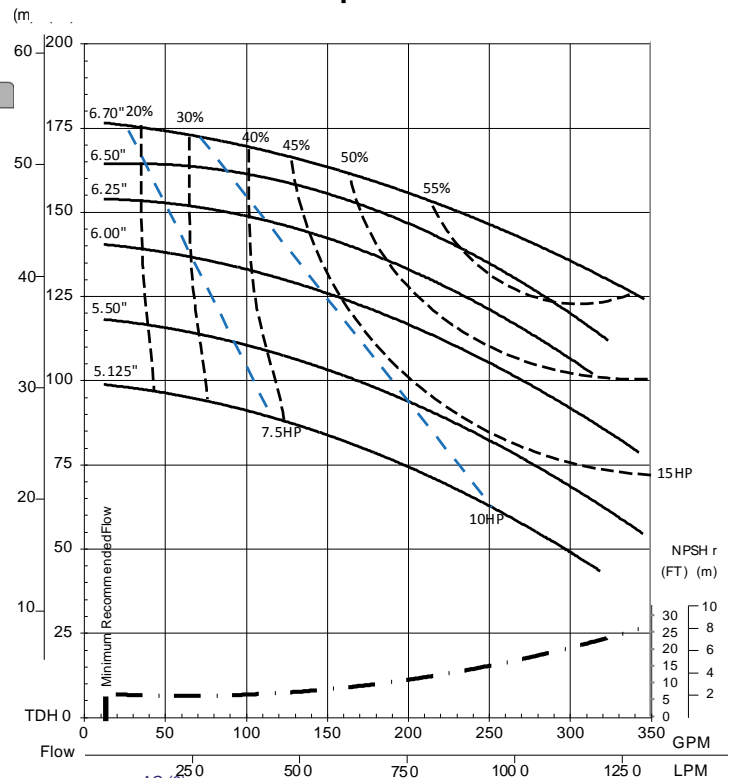

Dimensions (inches) and Specifications
Note: Will vary by motor manufacturer

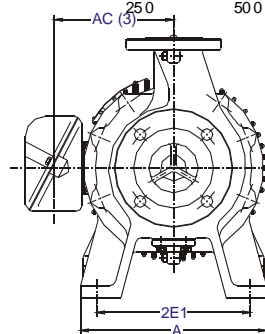
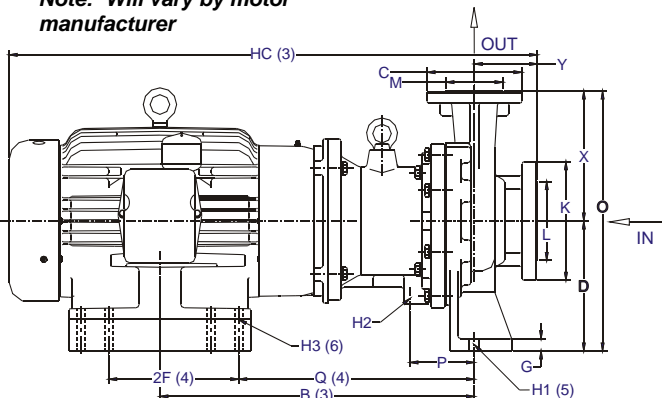

*Pump end only. Does not include motor.

Size	A	AC(3)	B(3)	D	2E1	2F(4)	G	H1(5)	H2	H3(4)	HC(3)	O	P	Q(4)	X	Y		
7.5-10	11.81	6.79	19.97	8.25	9.76	5.50/7.00	0.79	0.55	3/8-16UNC	0.41	28.53	16.50	4.09	14.46	8.25	4.00		
15-20		7.56				0.53				33.54				14.97				
25		10.56				0.53				37.35				14.97				
HP/Frame					Connection Sizes		Min Flow/Max Head		Standard Capacity		Max Capacity		Pump Weight*		K	L	C	M
7.5/213TC, 10/215TC, 15/254TC, 20/256TC, 25/284TSC					3 x 2		13/176		262		350		144		7.52	5.00	6.02	3.62