

MODEL	HP/ FRAME	PUMP FLANGES (2)	
		SUCTION	DISCHARGE
MXM-441	1/56C		
MXM-442	2/145TC	1.5"	1.5"

REVISIONS			
REV	DESCRIPTION	DATE	APPROVED

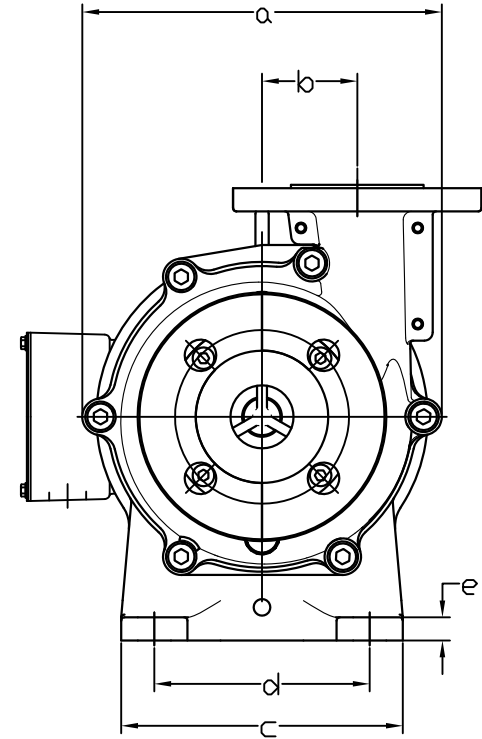
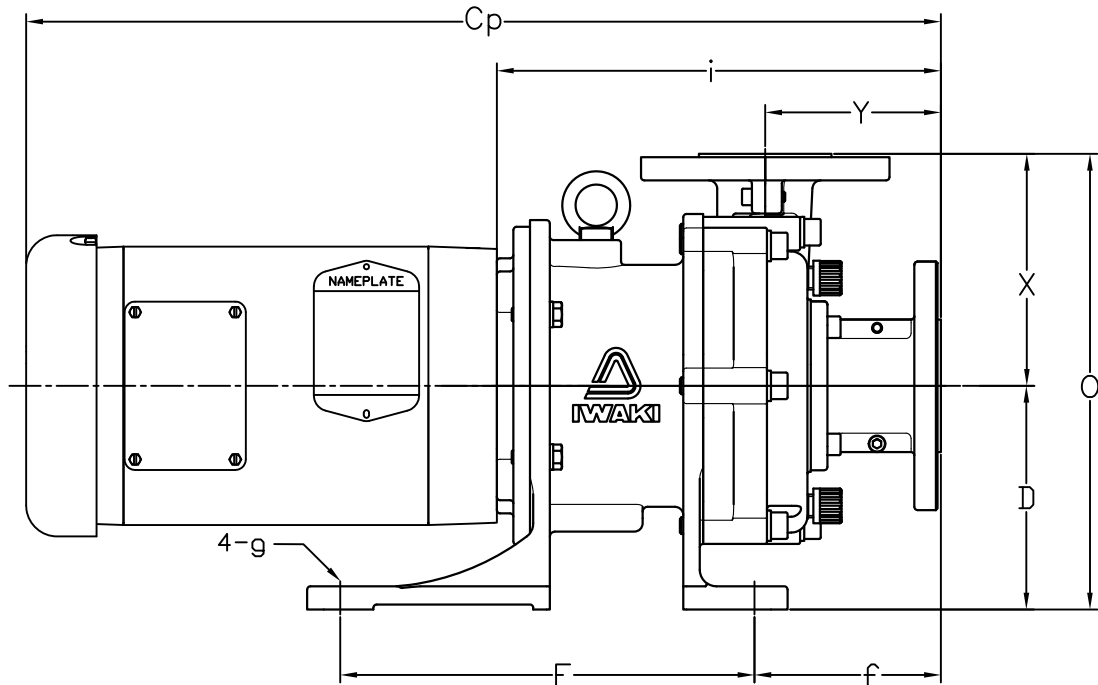

PUMP DIMENSIONS (1)														
a	b	c	d	D	e	f	F	g	i	D	X	Y	Cp <sup>(4)</sup>	Cp <sup>(5)</sup>
8.54	2.26	6.69	5.12	5.31	0.55	4.43	9.84	0.55	10.55	10.83	5.51	4.17	19.84	21.73

**NOTES AND REFERENCES:**

- (1) ALL DIMENSIONS IN INCHES. ALL TOLERANCES  $\pm .125"$ , CONSULT IWAKI AMERICA FOR MORE DETAILS.
- (2) BOLT HOLE LOCATIONS OF SUCTION AND DISCHARGE FLANGES CONFORM TO ANSI B16.5 150 LB STANDARD.
- (3) DRAWN PER 2B404285, 2B404545.
- (4) 1 HP MOTOR DIMENSION MIGHT VARY BASED ON MTR MFG.
- (5) 2 HP MOTOR DIMENSION MIGHT VARY BASED ON MTR MFG.
- (6) SHOWN WITH MTR1015, BALDOR 2HP, 145TC 3/60/230/460

<b>PROPRIETARY</b> THIS DRAWING CONTAINS CONFIDENTIAL INFORMATION PROPRIETARY TO IWAKI AMERICA. IT MUST NOT BE REPRODUCED OR FORWARDED TO OTHERS OR USED IN ANY OTHER WAY, IN WHOLE OR IN PART, UNLESS AUTHORIZED IN WRITING BY IWAKI AMERICA.		<b>TOLERANCES</b> DIMENSIONS IN INCHES (MM)  UNLESS OTHERWISE NOTED X = .050 .XX = .010 .XXX = .005  DEBURR AND BREAK ALL SHARP EDGES		 <b>IWAKI AMERICA</b> www.IwakiAmerica.com		5 Boynton Rd. Hopping Brook Park Holliston, MA 01746 (508) 429-1440	
MATERIAL <b>DUCTILE IRON</b>		BY CJC	DATE 11/23/2011	SIZE A	DWG NO. IALT-00221	DESCRIPTION MXM-44 MAG DRIVE PUMP	REV A
APPROVED JTS	DATE 11/28/2011	SCALE: FULL	THIRD ANGLE PROJECTION		SHEET:	1 OF 1	