

PART OR DRAWING NO. **IF20418** REV. **C**

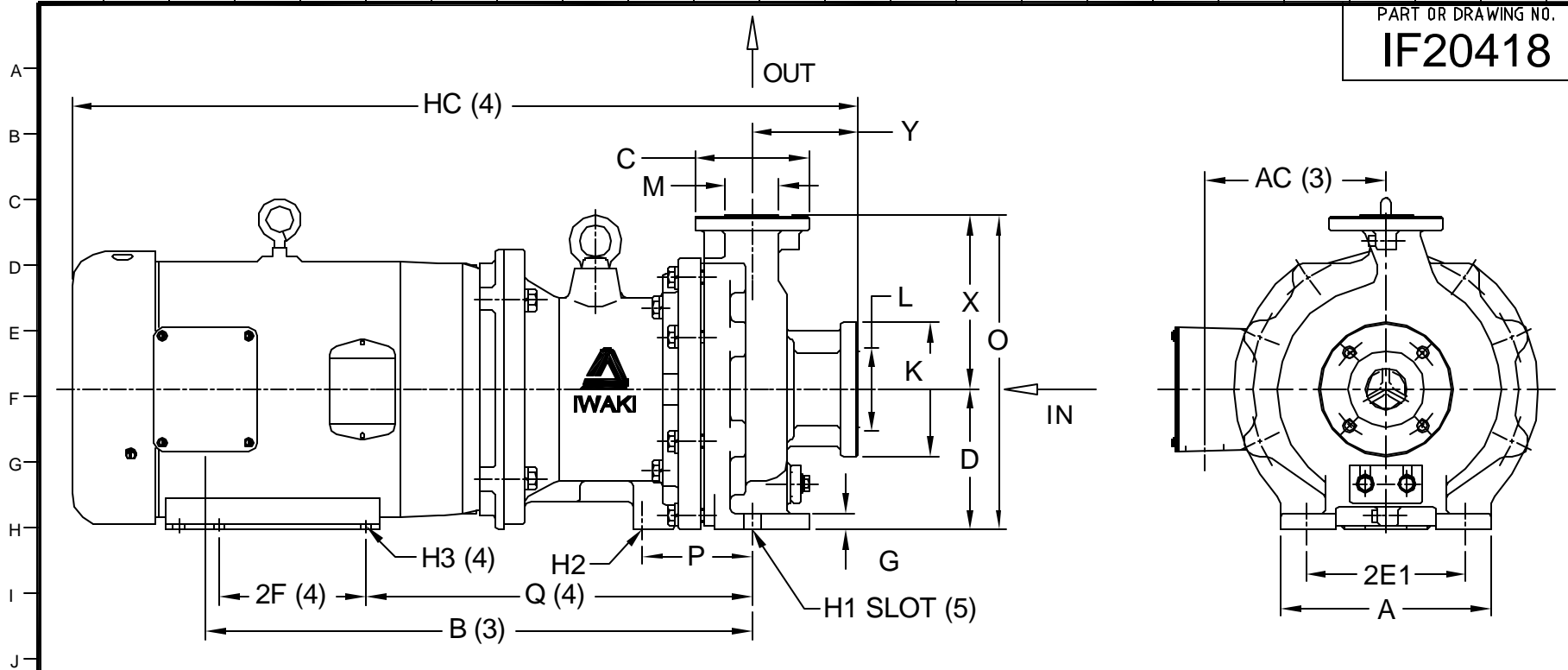

PUMP DIMENSIONS (1)															
A	AC (3)	B (3)	D	2E1	2F (4)	G	H1 (5)	H2	H3 (4)	HC (3)	O	P	Q (4)	X	Y
7.87"	6.79"	20.47"	5.26"	5.98"	5.50"/7.00"	0.59"	0.55"	3/8"-16 UNC	0.41"	29.47"	11.76"	4.09"	14.46"	6.50"	4.00"

MODEL	HP/ FRAME	PUMP FLANGES (2)		DIMENSIONS			
		SUCTION	DISCHARGE	K	L	C	M
MDM-1518	7.5/213TC	1 1/2"	1"	5.00"	3.15"	4.25"	2.01"
	10/215TC						

10619 CHANGED FORMAT AND EDITED: EDT 08-03-04										C
ECO#	DESCRIPTION				DATE				REV. LTR.	
	PUMP WEIGHT 132 LB				WET-END MATERIALS CFRETFE OR PFA					
EDT	03	08	04	CJC	1					
DRAWN	DAY	MO.	YR.	RELEASED	SHEET NO.					

 5 Boynton Rd.
 Hopping Brook Park
 Holliston, MA 01746
 (508) 429-1440
www.IwakiAmerica.com

TITLE **MDM-1518 (7.5 & 10 HP)** REV. **C**
 Dimensional Drawing

- NOTES AND REFERENCES:**
- (1) ALL DIMENSIONS IN INCHES. ALL TOLERANCES $\pm .125"$, CONSULT IWAKI AMERICA FOR MORE DETAILS.
 - (2) BOLT HOLE LOCATIONS OF SUCTION AND DISCHARGE FLANGES CONFORM TO ANSI B16.5 150 LB STANDARD. FLANGE BOLT HOLES HAVE 1/2" -13 UNC THREADS.
 - (3) DIMENSION MAY VARY BASED ON MOTOR MANUFACTURER.
 - (4) NEMA MG 1-1993, PART 4 USED FOR REFERENCE.
 - (5) SLOTS ARE OPEN ENDED TO SIDE OF FRAME.
- 6 PUMP DIMENSIONS BASED ON ANSI B73.3M-1997.
 7 DRAWN PER 2A401436 (MDM1518- F07A- 2)

PART OR DWG. NO. **IF20418**